

GL-8500 TETRODE

**RADIO-FREQUENCY AMPLIFIER
CW SERVICE
GROUNDED-GRID OPERATION**

**FORCED-AIR COOLED
METAL AND CERAMIC
INTEGRAL RADIATOR**

The GL-8500 is a reliable power tetrode that delivers useful output to 1250 megacycles or higher. This tube is particularly suitable for application in the final output or driver stage of military-communications systems.

As a Class B linear amplifier in the 225-400-megacycle range, the tube will deliver 110 watts of carrier power modulated up to 100 percent. Since a power gain of 20 may be realized, drive requirements are low—approximately 5 watts at carrier level.

Operating as a Class C CW amplifier at 900 megacycles, the gain is approximately 15 at the 200-watt level.

Features of the GL-8500 include long life and reliability, high gain, high linearity, and resistance to shock and vibration.

These together with such design factors as an oxide-coated cathode, coaxial elements, and metal-ceramic construction make the tube well adapted to application in modern systems where performance and reliability are important.

	Electrical			
	Minimum	Bogey	Maximum	
Heater Voltage*	—	6.3	6.8	Volts
Heater Current	—	3.8	—	Amperes
Cathode Heating Time	1	—	—	Minutes
Amplification Factor, G ₂ to G ₁ , E _b = 1000V DC; E _a = 275V DC; I _b = 0.2 A DC	—	14	—	
Peak Cathode Current†	—	—	1.75	Amperes
Direct Interelectrode Capacitances				
Cathode to Plate‡	—	0.006	—	μf
Input, G ₂ tied to G ₁	—	19.5	—	μf
Output, G ₂ tied to G ₁ §	—	6.4	—	μf

Mechanical	
Mounting Position—Any	
Net Weight, approximate	1.0 Pounds

Thermal			
Cooling—Forced Air§ Through Radiator, at Sea Level**			
Plate Dissipation...	500	400	300 Watts
Air Flow, 45 C In- coming Air Tem- perature, mini- mum.....	17.0	12.0	6.5 Cubic Feet per Minute
Static Pressure, ap- proximate.....	0.9	0.5	0.2 Inches- Water
Radiator Hub Tem- perature, at Point Adjacent to Anode Seal.....	—	—	250 C
Seals			
Screen-Grid to Con- trol-Grid, approxi- mate.....	—	—	1 Cubic Feet per Minute
Heater to Cathode, approximate.....	—	—	1 Cubic Feet per Minute
Ceramic Temperature at Any Point, maxi- mum.....	—	—	200 C

GENERAL  ELECTRIC

RADIO-FREQUENCY POWER AMPLIFIER—CLASS B LINEAR

Carrier conditions per tube for use with a maximum modulation factor of 1.0

Maximum Ratings

DC Plate Voltage.....	2000	Volts
DC Grid-No. 2 Voltage.....	320	Volts
DC Plate Current.....	0.250	Amperes
Plate Input.....	500	Watts
Grid-No. 2 Input.....	5	Watts
Plate Dissipation.....	500	Watts

Typical Operation

Grounded-Grid Circuit at 225-400 Megacycles		
DC Plate Voltage.....	1750	Volts
DC Grid-No. 2 Voltage.....	250	Volts
DC Grid-No. 1 Voltage, approximate.....	-20	Volts
Peak RF Plate Voltage #, approximate.....	1250	Volts
Peak RF Grid-No. 1 Voltage #, approximate.....	40	Volts
DC Plate Current.....	0.200	Amperes
Zero Signal DC Plate Current (E _{cl} adjusted).....	0.020	Amperes
DC Grid-No. 2 Current.....	0.005	Amperes
DC Grid-No. 1 Current.....	0.010	Amperes
Driving Power, approximate.....	5	Watts
Power Output ♡.....	110	Watts

RADIO-FREQUENCY POWER AMPLIFIER AND OSCILLATOR—CLASS C TELEGRAPHY

Key-down conditions per tube without amplitude modulation Δ

Maximum Ratings

	900 Megacycles	400 Megacycles	
DC Plate Voltage.....	1600	2000	Volts
DC Grid-No. 2 Voltage.....	320	320	Volts
DC Grid-No. 1 Voltage.....	-100	-100	Volts
DC Plate Current.....	0.300	0.300	Ampere
DC Grid-No. 1 Current.....	0.050	0.050	Ampere
Plate Input.....	480	600	Watts
Grid-No. 2 Input.....	15	15	Watts
Plate Dissipation.....	500	500	Watts
Grid-No. 1 Dissipation.....	2	2	Watts

Typical Operation

Grounded-Grid Circuit at 900 Megacycles			
DC Plate Voltage.....	1500	2000	Volts
DC Grid-No. 2 Voltage.....	210	225	Volts
DC Grid-No. 1 Voltage.....	-40	-40	Volts
DC Plate Current.....	0.300	0.250	Ampere
DC Grid-No. 2 Current, approximate.....	0.010	0.010	Ampere
DC Grid-No. 1 Current, approximate.....	0.020	0.020	Ampere
Driving Power, approximate.....	14	15	Watts
Power Output, approximate †.....	205	300	Watts

* Because the temperature of the cathode is increased by back bombardment of electrons at UHF, required heater voltage for optimum life decreases with increasing frequency. The amount of heater-voltage reduction is dependent on operating conditions. However, this voltage should not be less than 5.5 volts.

† Represents maximum usable cathode current (plate current plus current to each grid) for any condition of operation.

‡ Measured with a 6-inch minimum diameter flat metal disk attached to the screen-grid ring. Control grid connected to the screen grid.

♦ Output capacitances measured between anode and screen grid. Control grid connected directly to screen grid.

§ Forced-air cooling to be applied before and during the application of any voltages.

**Provision must be made for unobstructed passage of cooling air between radiator fins and between the anode terminal and adjacent radiator fin.

♡ Useful power output as measured in output-circuit load.

†† Useful power output including power transferred from driver stage. Output circuit efficiency approximately 80 percent.

Δ Modulation essentially negative may be used if the positive peak of the envelope does not exceed 115 percent of the carrier conditions.

CONSTANT CURRENT CHARACTERISTIC
 SCREEN VOLTAGE = 250 VOLTS
 ALL VOLTAGES REFERENCED TO CONTROL GRID

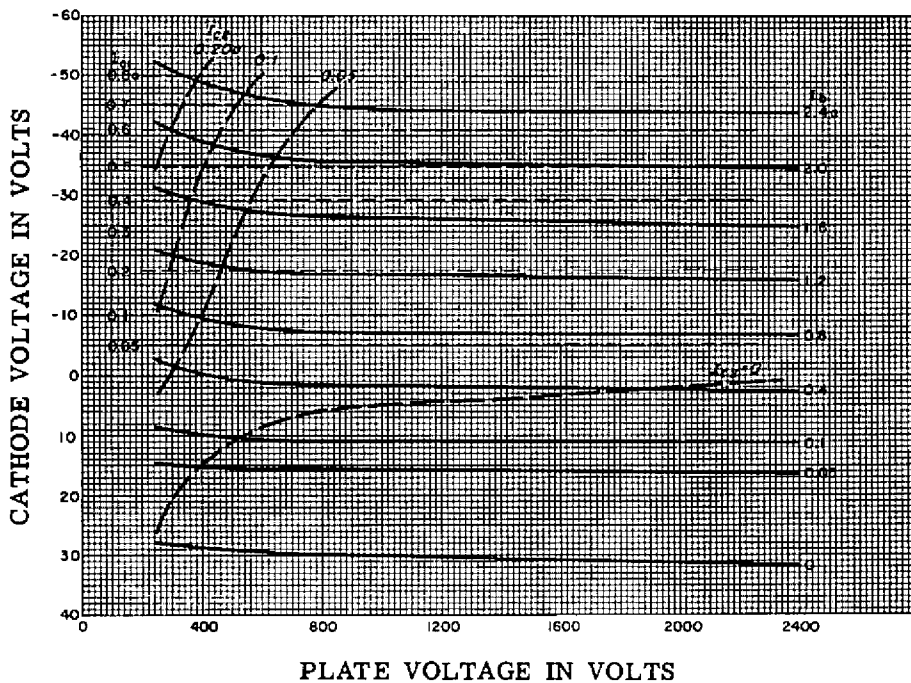

A69087 - 72B67

1-30-63

CONSTANT CURRENT CHARACTERISTIC
 SCREEN VOLTAGE = 350 VOLTS
 ALL VOLTAGES REFERENCED TO CONTROL GRID

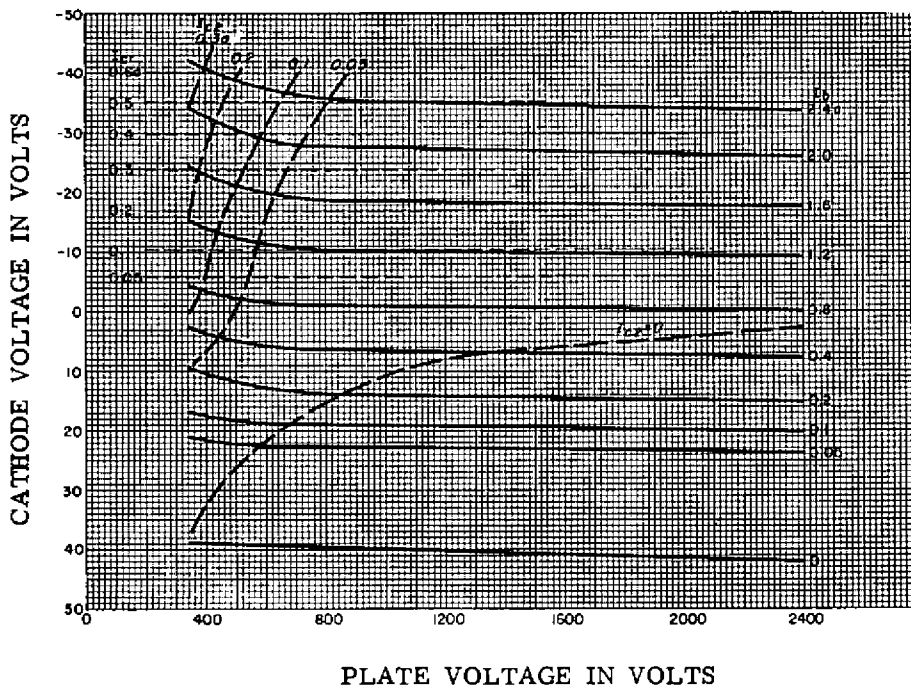

A69087 - 72B68

1-30-63

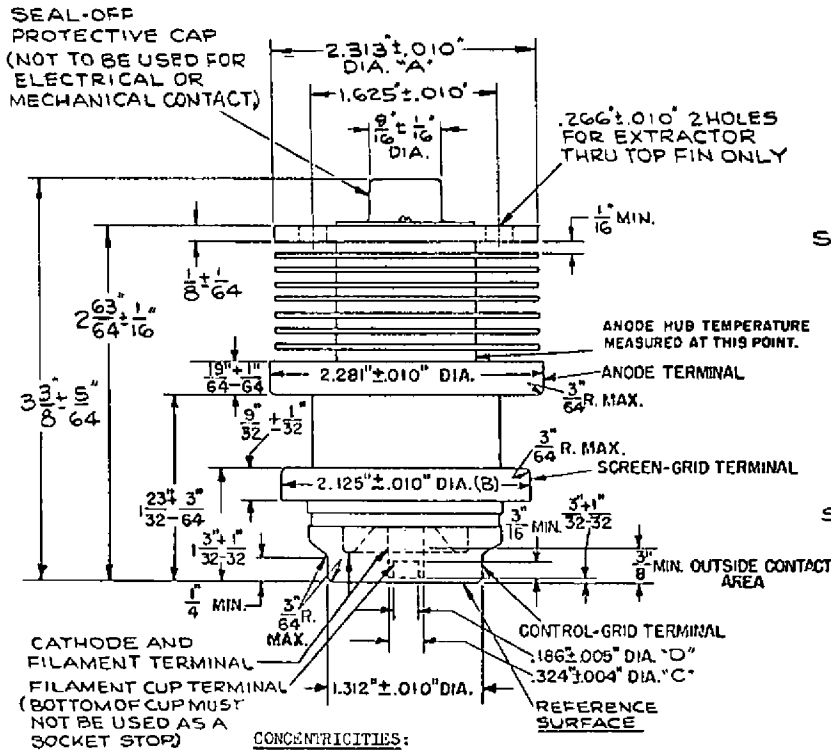

The following total indicator readings are measured with respect to a centerline determined by the centers of the anode terminal and control grid terminal.

- Diameter A - 0.030 inches
- Diameter B - 0.016 inches
- Diameter C - 0.036 inches
- Diameter D - 0.042 inches

Total indicator reading of filament cup terminal diameter (D) measured with respect to center of cathode and filament terminal diameter (C) - 0.016 inches.

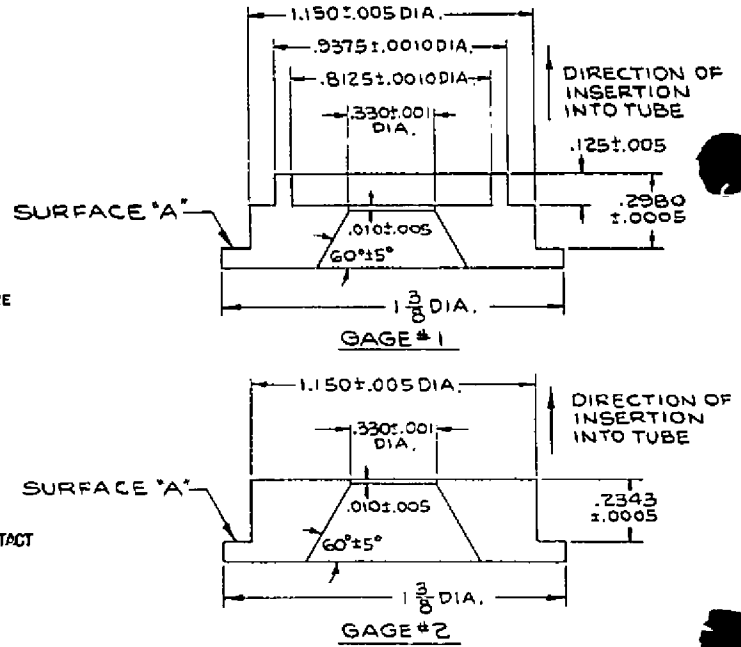

ZP-1030
CATHODE AND FILAMENT TERMINAL GAGES

When inserted over the cathode and filament terminal, gage #1 shall not contact the tube REFERENCE SURFACE at gage SURFACE "A".

When inserted over the cathode and filament terminal, gage #2 shall contact the tube REFERENCE SURFACE at gage SURFACE "A".