

**IGNITRON  
 Coaxial**

**RECTIFIER SERVICE—190 AMPERES  
 AC CONTROL SERVICE—355 AMPERES**

**ADAPTED TO WATER-FLOW  
 CONTROL**

**ADAPTED TO TEMPERATURE  
 CONTROL**

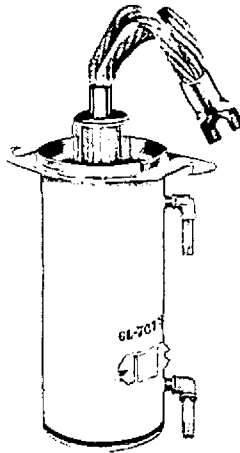

The GL-7673 is a sealed, stainless-steel-jacketed, water-cooled ignitron for a-c control service. In such application two tubes in inverse-parallel connection will control 2400 kilovolt-amperes at voltages of 250 to 600 over a frequency range of 25 to 60 cycles.

The 7673 features a new coaxial construction in which current flows through the tube from anode to cathode, then up the tube wall to a coaxial cathode terminal at the top. This coaxial current flow provides a magnetic shield to eliminate the arc deflection which the high

peak currents of this tube might cause in standard design ignitrons.

A slotted mounting plate permits convenient mounting of a thermostat to provide control of the water flow or over-temperature protection.

Advantages of the control feature include reduction of condensation on the tube walls during hot weather, protection against overloads, elimination of water supply as a limiting factor in equipment location, and appreciable savings in water consumption.

**Electrical**

Cathode Excitation—Cyclic	
Cathode Spot Starting—Ignitor	
Number of Electrodes	
Main Anodes.....	1
Main Cathodes.....	1
Ignitors.....	1
Arc Drop at 13,600 Amperes Peak.....	36 Volts
Arc Drop at 1115 Amperes Peak.....	17 Volts

**Mechanical**

Envelope Material—Stainless Steel	
Net Weight.....	21 Pounds

**Thermal**

Type of Cooling—Water	
Inlet Water Temperature, minimum..	0 C
Inlet Water Temperature, maximum..	30 C
Outlet Water Temperature, maximum..	40 C
Water Flow, minimum, solenoid water valve open.....	3.0 Gallons per Minute
Characteristics for Water Cooling at Rated Minimum Flow	
Water Temperature Rise, maximum..	9 C
Pressure Drop at 3 Gallons per Minute, maximum.....	5.1 Pounds per Square Inch

**MAXIMUM RATINGS**

**Power-Rectifier Service, Intermittent Duty**

*Ratings are for Zero-Phase-Control Angle (See Curves K-69087-72A513 and K-69087-72A630 on Page 2 for Details)*

*Ratings Apply Only at Inlet Water Temperatures Up to 40 C*

Maximum Peak Anode Voltage			
Inverse.....	600	1200	1500 Volts
Forward.....	600	1200	1500 Volts
Maximum Anode Current			
Peak.....	4000	3000	2400 Amperes
Corresponding Average.....	54	40	32 Amperes
Average.....	190	140	112 Amperes
Corresponding Peak.....	1140	840	672 Amperes
Maximum Averaging Time.....	6.23	6.25	6.25 Seconds
Ratio of Average to Peak Current, maximum			
Averaging Time 0.2 Second.....	0.166	0.166	0.166
Ratio of Fault to Maximum			
Peak Current.....	12.5	12.5	12.5
Maximum Duration of Fault			
Current.....	0.15	0.15	0.15 Seconds
Frequency Range.....	50-60	50-60	50-60 Cycles per Second

**AC Control Service\***

*Two Tubes in Inverse Parallel, Ratings per Tube (See Curves K-69087-72A723 and K-69087-72A724 on Page 3 for Details)*

Voltage.....	250 to 600 Volts RMS
Maximum Demand.....	2400 Kilovolt-Amperes
Average Current at Maximum Demand.....	192 Amperes
Maximum Average Current.....	355 Amperes
Demand at Maximum Average Current.....	800 Kilovolt-Amperes
Maximum Averaging Time at 250 Volts RMS.....	11.0 Seconds
Maximum Averaging Time at 600 Volts RMS.....	4.6 Seconds
Maximum Peak Fault-Current at 250 Volts.....	27,000 Amperes
Maximum Peak Fault Current at 600 Volts.....	11,200 Amperes
Frequency Range.....	25-60 Cycles per Second

**Cathode Excitation Requirements**

Ignitor Voltage Required to Fire.....	200 Volts
Ignitor Current Required to Fire.....	30 Amperes
<i>(See Curve K-69087-72A982 on Page 4 for Ignitor Circuit Requirements)</i>	
Starting Time at Required Voltage or Current.....	100 Microseconds

Ignitor	
Maximum Voltage	
Positive—Anode Voltage	
Negative.....	5 Volts
Maximum Current	
Peak.....	100 Amperes
Root Mean Square.....	10 Amperes
Average.....	1 Ampere
Maximum Averaging Time.....	5 Seconds

\* RMS demand voltage, current, and kilovolt-ampere demand are all on the basis of full-cycle conduction (no phase delay) regardless of whether or not phase control is used. For voltages below the minimum, the minimum-voltage current rating applies. With the use of log-log paper straight-line interpolation between tabulated points may be used for other detailed ratings of: Demand kva vs average anode current, and maximum averaging time vs anode voltage.

PHASE CONTROL  
THREE-PHASE SINGLE-WAY  
DOUBLE-WAY CIRCUITS

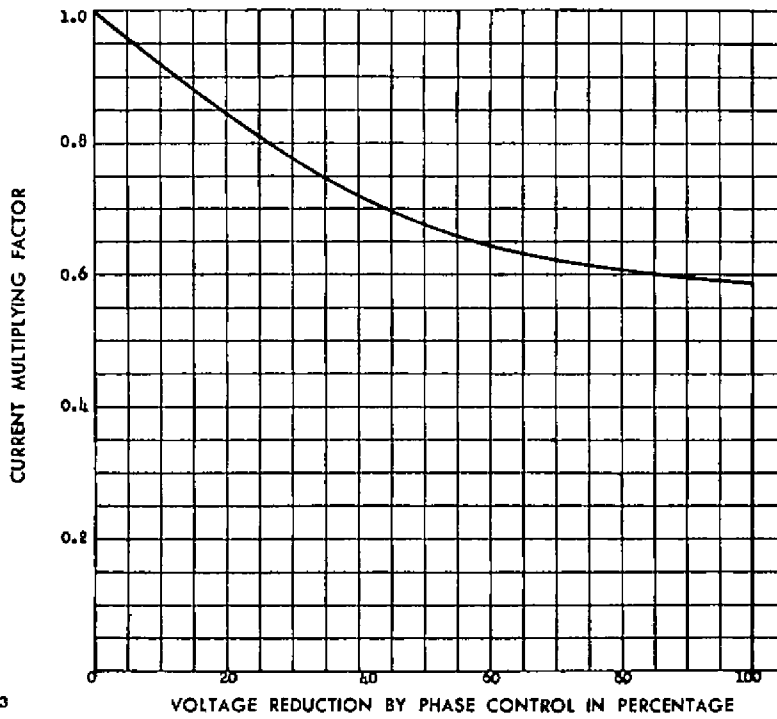

K-69087-72A513

8-21-53

POWER-RECTIFIER RATING—INTERMITTENT DUTY

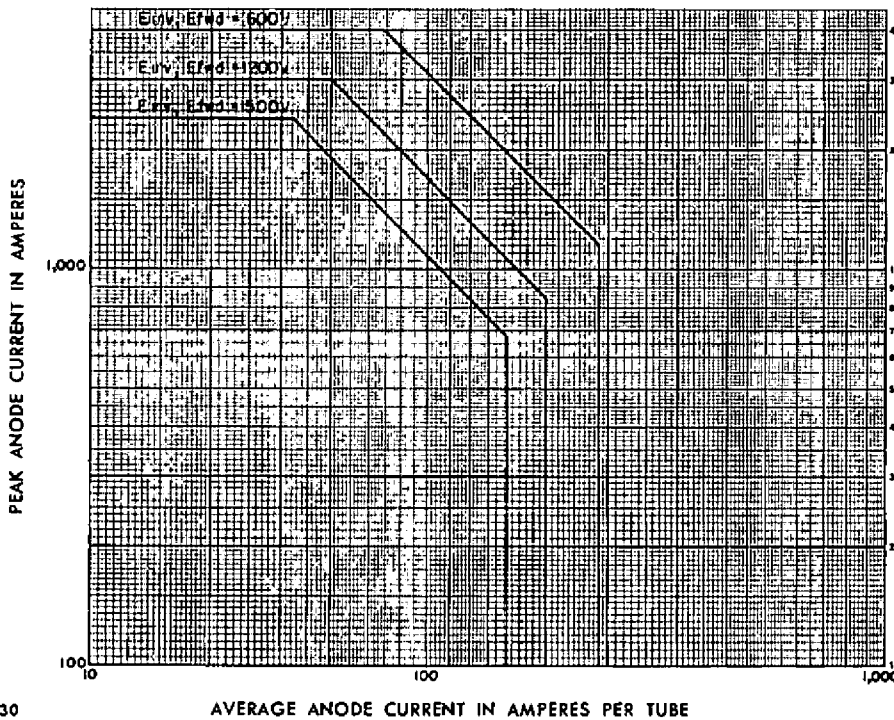

K-69087-72A630

9-21-55

MAXIMUM AVERAGING TIME=6.25 SECONDS

$I_{AVERAGE}$  MAXIMUM AVERAGING TIME 0.2 SECONDS = 0.166 MAXIMUM

$I_{PEAK}$

$I_{FAULT}$  MAXIMUM DURATION OF FAULT CURRENT 0.15 SECONDS = 12.5 MAXIMUM

$I_{PEAK MAX.}$

DEMAND CURRENT VS PERCENTAGE DUTY AT 220 TO 250 VOLTS RMS

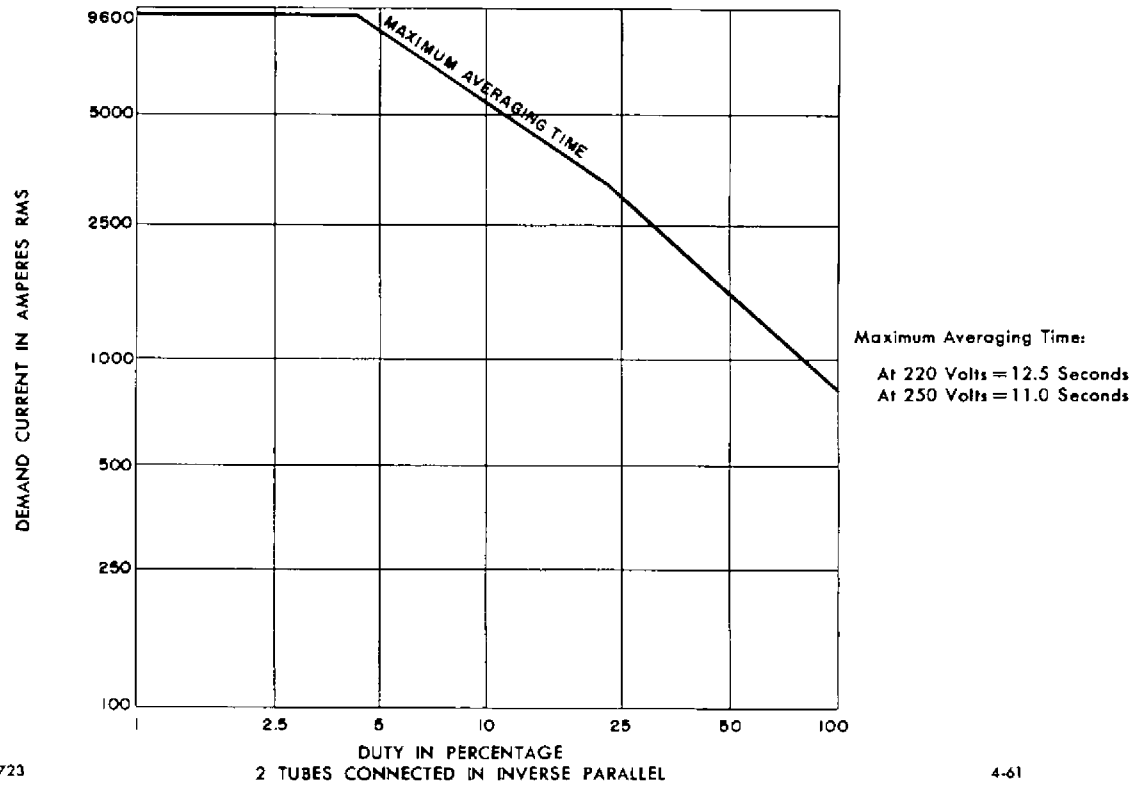

K-69087-72A723

4-61

DEMAND CURRENT VS PERCENTAGE DUTY AT 440 TO 600 VOLTS RMS

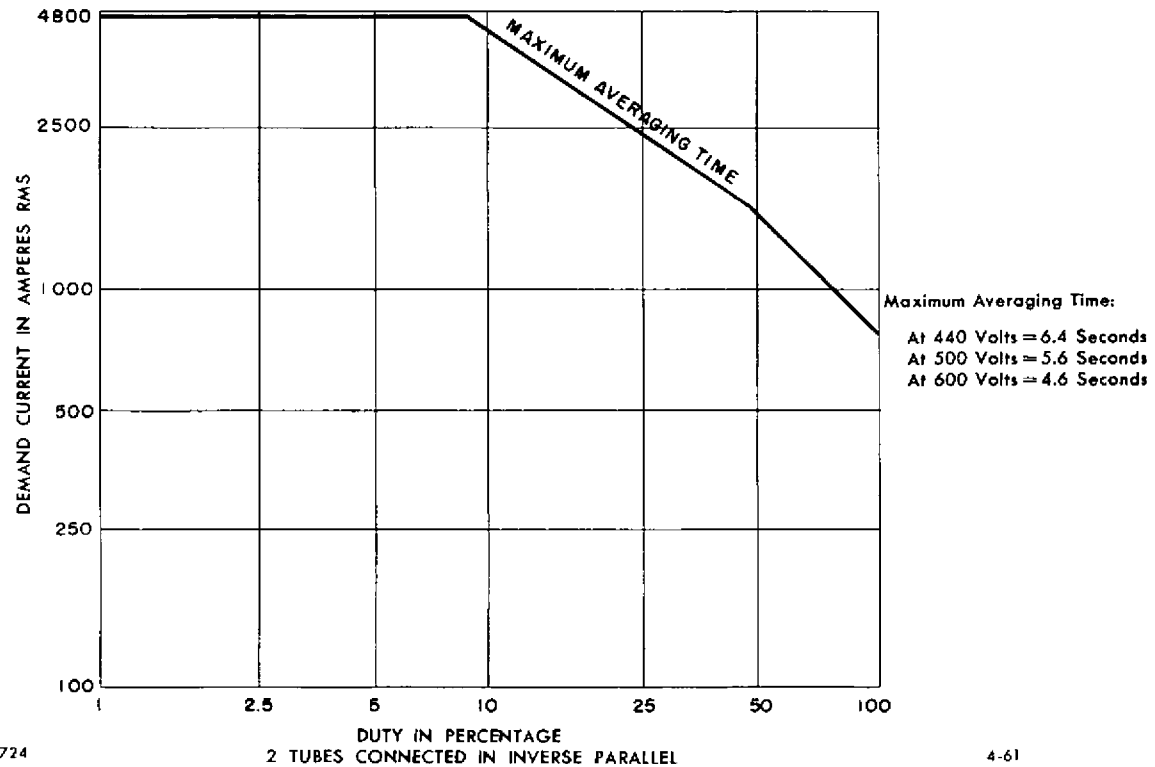

K-69087-72A724

4-61

### IGNITOR VOLT-AMPERE REQUIREMENTS FOR SEPARATE EXCITATION SEALED-IGNITRON RECTIFIERS

THE IGNITOR FIRING CIRCUIT SHOULD BE DESIGNED  
TO OPERATE WITHIN THE SHADED AREA

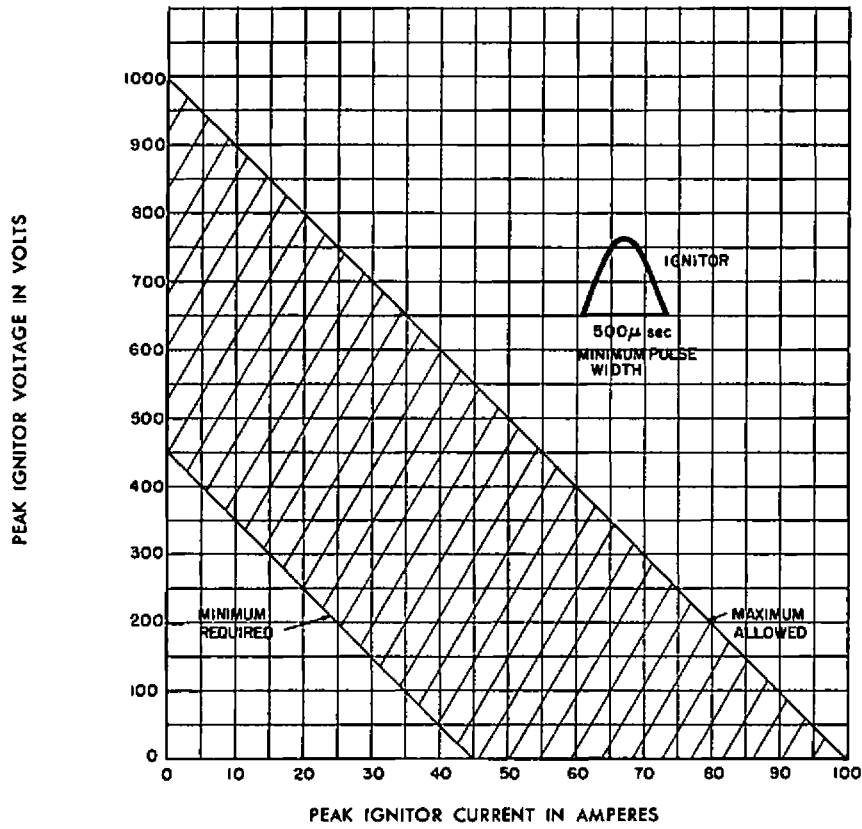

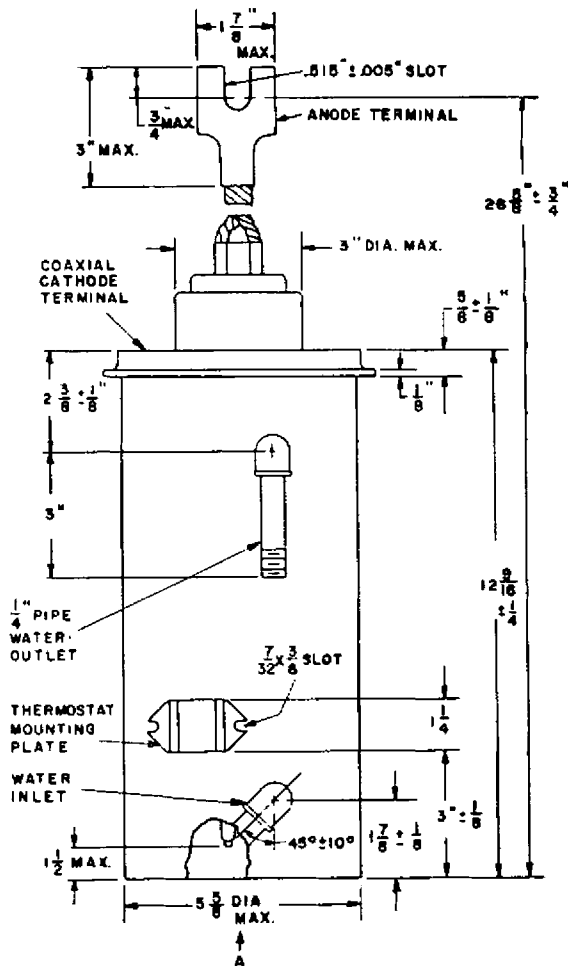

Control thermostats, with mounting brackets, are available through regular tube supply channels under the following catalog numbers:

**AC Control Service**

**Flying-Lead Type**

Water-Control Thermostat—N15272AA

Over-Temperature Thermostat—N15273AA

**Terminal-Block Type**

Water-Control Thermostat—N15286AA

Over-Temperature Thermostat—N15287AA

See Ignitron Accessories publication in front of Ignitron section for details.

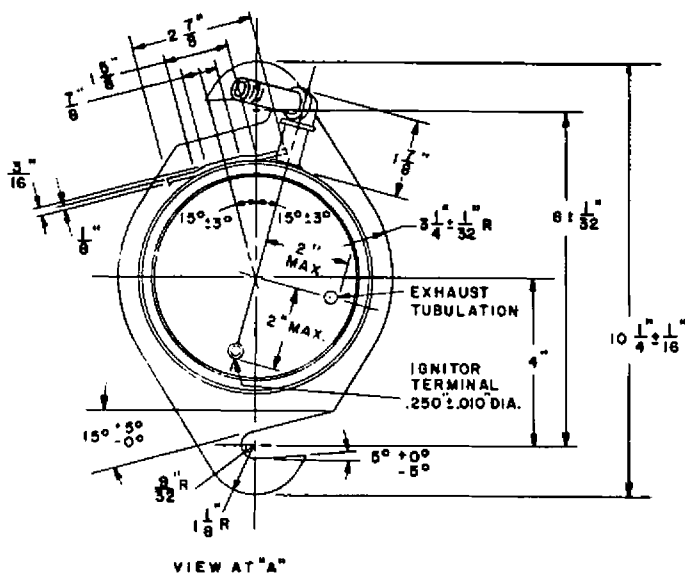

from JEDEC release #3274A,  
 Sept. 23, 1963

